



TITAN CUSTOM FENCE SYSTEM

Titan Custom steel fence systems are as strong and durable as the name implies and are designed to meet the stringent requirements essential for commercial, industrial and federally specified projects.

Available in both commercial and industrial sizes, Titan Custom is manufactured with 100% domestic G90 steel and carries a full 20 year warranty.

Panels are engineered with a patented slide lock rail system for added strength and security, and are factory assembled to minimize installation time and ensure structural integrity.

Prior to assembly, the galvanized steel fence components are coated with *Fortress Armour*, a premium coating process which includes a zinc rinse, an epoxy primer and premium grade powder top coat. This professionally applied coating process produces long lasting, worry free performance.





TITAN FEATURES

- 24" of Adjustability in an 8' Section
- 100% Domestic G90 Steel
- Premium Dual Powder Coat
- Fully Pre-Assembled
- Manufactured in the USA
- Slide Lock Rail
- 20 Year Limited Warranty

FortressArmour Powder Coat Process

Titan Custom pickets, posts and rails are produced with 45,000 PSI, 100% domestic G90 steel and all components receive the *FortressArmour* powder coat process.

Galvanized components are thoroughly cleaned and sent through a zinc rinse application. After the final rinse and drying cycle, the components are coated with a corrosion resistant epoxy powder coat, followed by a premium grade powder top coat. This high-end *FortressArmour* coating process ensures that each Titan Custom Fence system will provide years of worry free performance.

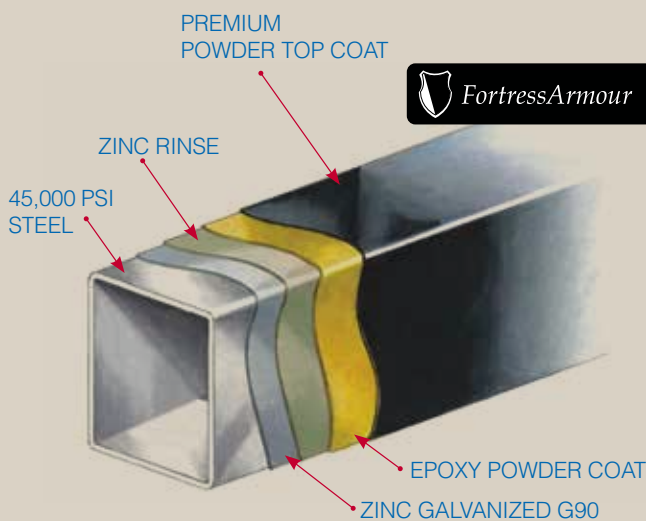

Titan Custom Adjustability

Titan Custom panels are designed to easily accommodate changes in ground elevations, and both the commercial and industrial panels provide 24" of adjustability per 8' section. This added benefit eliminates the need for costly and time consuming stair stepping, and produces a smoother, more professional appearance.

24" of Adjustability in an 8' Section

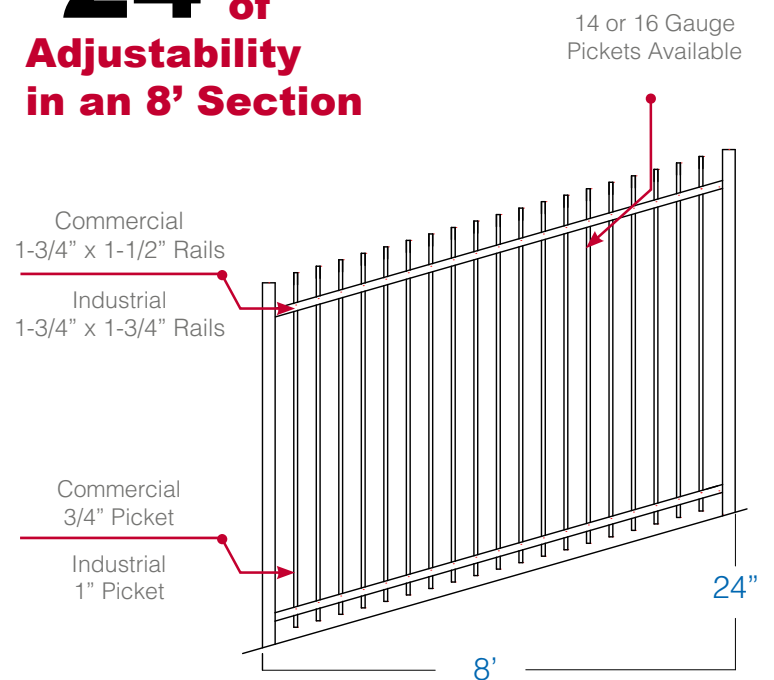



FLAT TOP

A clean design with no pickets above the top rail.

Available in 2 or 3 rail styles.

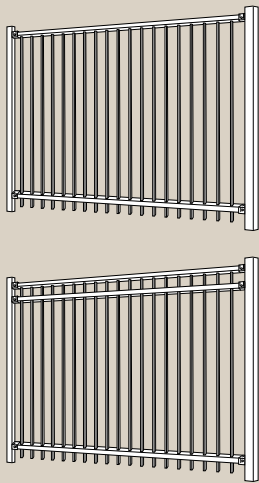

EXTENDED PICKET

A traditional design with square top pickets.

Available in 2 or 3 rail styles.

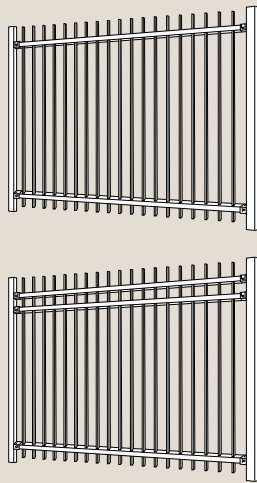

PRESSED SPEAR

A secure and elegant design with pressed spear pickets.

Available in 2 or 3 rail styles.

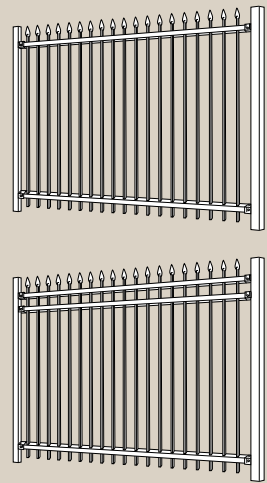

Gates

A large selection of standard and custom gate sizes and styles are available to coordinate with the TITAN Custom fence system. Consult your local Merchants Metals sales representative for more information about our wide array of gates and gate hardware.

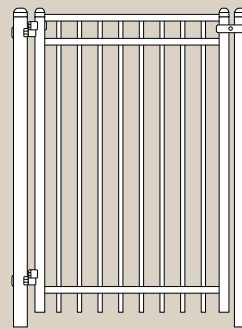

Flat Top Walk Gate

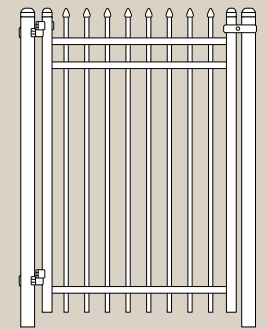

Pressed Spear Walk Gate

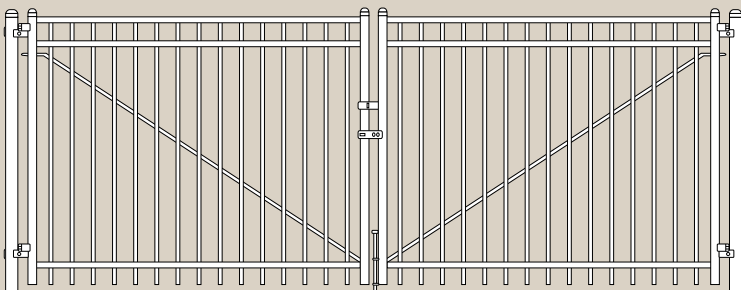

Drive Gate / Swing Gate

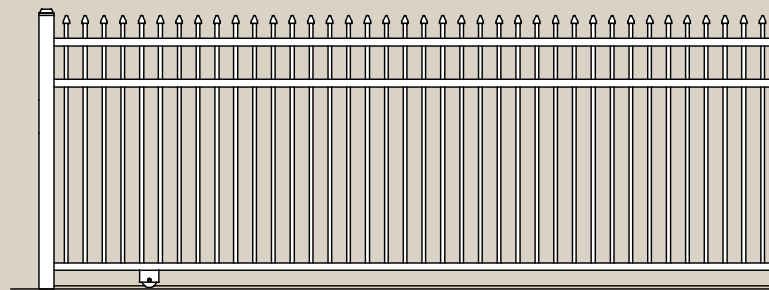

V-Track Roll Gate



CURVED TOP

A high security design with curved press spear pickets.

Available in 2 or 3 rail styles.

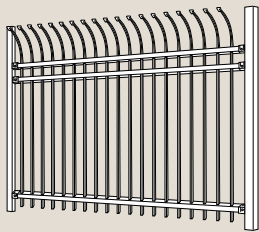
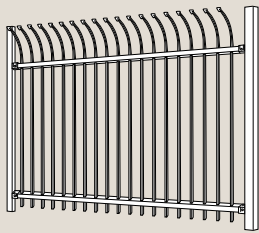

SIDE BY SIDE COMPARISON

	COMMERCIAL	INDUSTRIAL
PICKETS	3/4" x 3/4" x 16 ga.	1" x 1" x 16 ga. or 14 ga.
RAILS	1-3/4" x 1-1/2" x 16 ga.	1-3/4" x 1-3/4" x 14 ga.
RAIL SLIDE LOCK	G90 Galvanized Steel - 18 ga.	G90 Galvanized Steel - 18 ga.
POSTS	2-1/2" x 2-1/2" x 14 ga.	2-1/2" x 2-1/2" x 14 ga.
OPTIONAL POSTS	2-1/2" x 2-1/2" x 16 ga. 3" x 3" x 12 ga. 4" x 4" x 11 ga.	2-1/2" x 2-1/2" x 16 ga. 3" x 3" x 12 ga. 4" x 4" x 11 ga.
PICKET SPACING	3-15/16" Air Space	3-15/16" Air Space
HEIGHTS AVAILABLE	34", 46", 58", 70", 82", 94"	34", 46", 58", 70", 82", 94", 106", 118", 130", 142"
WIDTHS AVAILABLE	8'	8'
ALLOY	G90 Galvanized Steel	G90 Galvanized Steel
FULLY ASSEMBLED	8' On Center Spacing (Based on 2-1/2" posts)	8' On Center Spacing (Based on 2-1/2" posts)
PANEL STYLES	Flat Top, Extended Picket, Pressed Spear	Flat Top, Extended Picket, Pressed Spear, Curved Top
RAIL STYLES	2 & 3 Rail 4 Rail Available Upon Request	2 & 3 Rail 4 Rail Available Upon Request
SPECIFIED FOR	Educational Campuses, Housing Complexes, Community & Public Pools, Apartment Complexes, Office Buildings, Parking Facilities	Military Installations, Energy Plants, Water Treatment Facilities, Stadiums & Event Centers, Universities, Hospitals

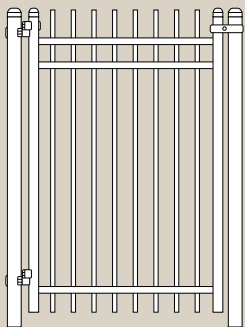

Extended Picket Walk Gate

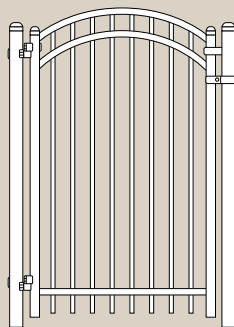

Flat Top Arched Walk Gate

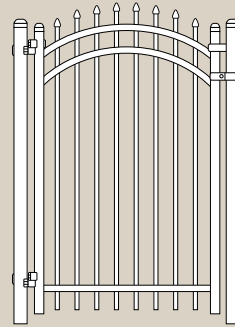

Pressed Spear Arched Walk Gate

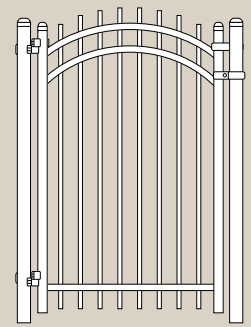

Extended Picket Arched Walk Gate

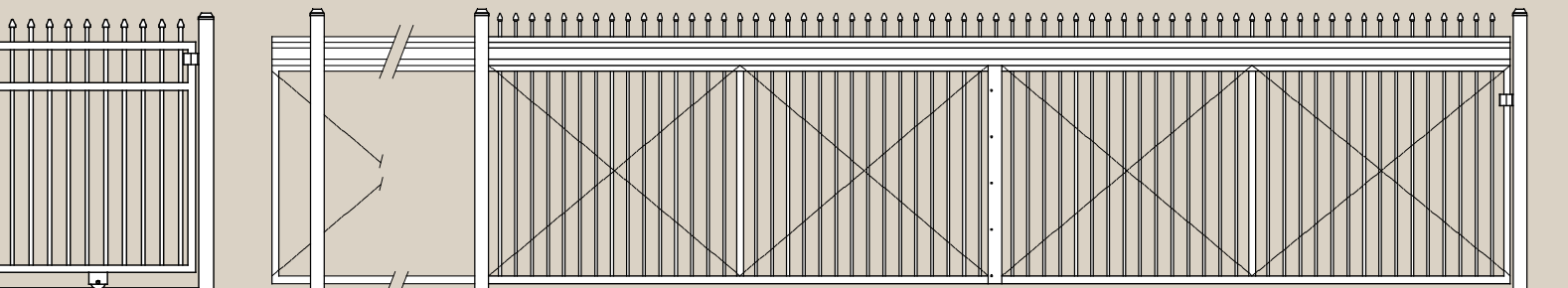

Cantilever Gate

SLIDE LOCK RAIL

**680 lb Mid-Span
Load Per Rail**



ACCESSORIES / HARDWARE



COLOR OPTIONS



SPECIFIED FOR

COMMERCIAL

- Educational Campuses
- Housing Complexes
- Community & Public Pools
- Apartment Complexes
- Office Buildings
- Parking Facilities

INDUSTRIAL

- Military Installations
- Energy Plants
- Water Treatment Facilities
- Stadiums & Event Centers
- Universities
- Hospitals

