

- NOTES:
1. SPECIFICATIONS SHOWN CAN BE CHANGED BY THE MANUFACTURER ONLY.
  2. ALL COMPONENTS OF THE GATE TO BE COATED BLACK.
  3. VERIFY POST DEPTH AND FOOTING DIMENSIONS WITH LOCAL CODES AND SITE CONDITIONS.
  4. CUSTOM DIMENSIONS ARE AVAILABLE UPON REQUEST
  5. OUTSIDE LOOKING IN, GATE LATCHES IN THE MIDDLE
  6. GATE OPENINGS OVER 16' WILL REQUIRE ADDITIONAL SUPPORT
  7. POST SIZE WILL VARY DEPENDING UPON WIDTH AND HEIGHT OF GATE \* SEE NOTE 3 TO VERIFY

ARCH CHART	
WIDTH OF OPENING	HEIGHT OF ARCH
6' - 8'	12"
8'-10'	15"
10' OR MORE	15" - 24"

POST DEPTH CHART*	
HEIGHT OF GATE	POST BELOW GRADE
5' OR LESS	2'
6' OR MORE	3'

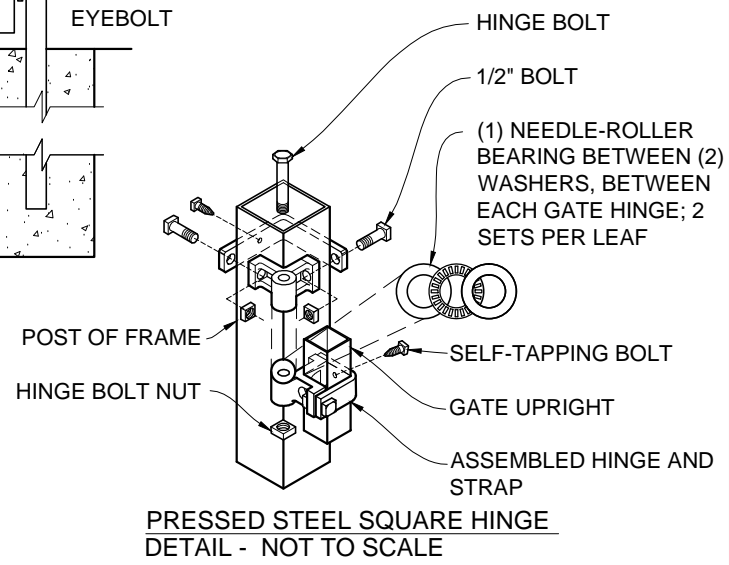

**Merchants Metals**  
*the first name in fence solutions*

**GUARDSMAN GATE - KENT**  
 DOUBLE DRIVE SIMPLE ARCH 2 TO 4 RAILS  
 6' TO 40' WIDE OPENING x 3' TO 12' HIGH  
 (Nom.Dimension)

BY: J.R.  
 DATE: 13 SEPT 13  
 REV: D.D.

DWG. NO.  
 GM SA COM KN 3-20W x 3-12H DD  
 SCALE:  
 AS NOTED