

- NOTES:
1. SPECIFICATIONS SHOWN CAN BE CHANGED BY THE MANUFACTURER ONLY.
  2. ALL COMPONENTS OF THE GATE TO BE COATED BLACK. OTHER COLORS AVAILABLE UPON REQUEST.
  3. VERIFY POST DEPTH AND FOOTING DIMENSIONS WITH LOCAL CODES AND SITE CONDITIONS.
  4. CUSTOM DIMENSIONS ARE AVAILABLE UPON REQUEST. FOR HIGHER CUSTOM GATES, PLEASE CONTACT THE STATESVILLE PLANT.
  5. OUTSIDE LOOKING IN, GATE LATCHES ON \_\_\_\_\_ (RIGHT AS SHOWN)
  6. FOR LARGER CUSTOM GATES, PLEASE CONTACT THE STATESVILLE PLANT. GATE OPENINGS OVER 8' WILL REQUIRE ADDITIONAL SUPPORT.
  7. POST SIZE WILL VARY DEPENDING UPON WIDTH AND HEIGHT OF GATE.

POST DEPTH CHART*	
HEIGHT OF GATE	POST BELOW GRADE
5' OR LESS	2'
6' OR MORE	3'

\* SEE NOTE 3

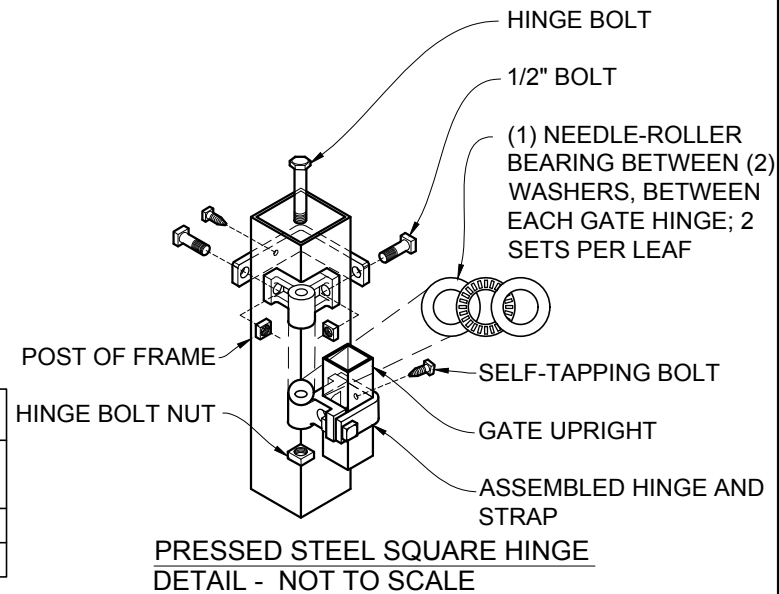

PRESSED STEEL SQUARE HINGE  
DETAIL - NOT TO SCALE