

SECURE TRAC CANTILEVER SLIDE GATE
PLAN 1/8"=1'-0"

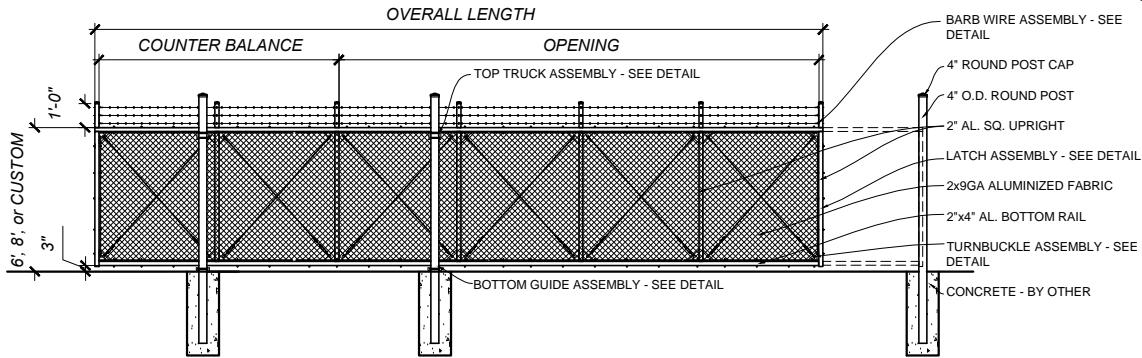

SECURE TRAC CANTILEVER SLIDE GATE
ELEVATION - OUTSIDE LOOKING IN 1/8"=1'-0"

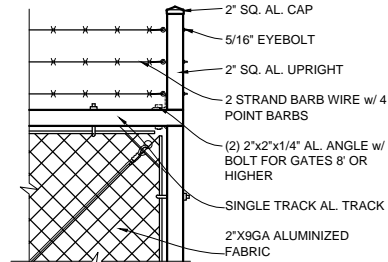

BARB WIRE ASSEMBLY
DETAIL 1/2"=1'-0"

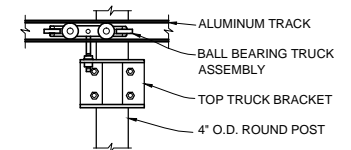

TOP TRUCK ASSEMBLY
DETAIL 1/2"=1'-0"

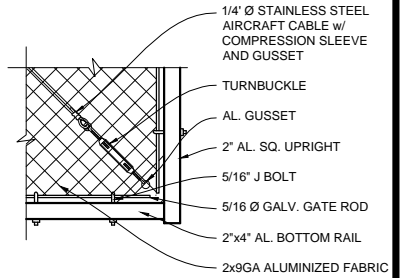

TURNBUCKLE ASSEMBLY
DETAIL 1/2"=1'-0"

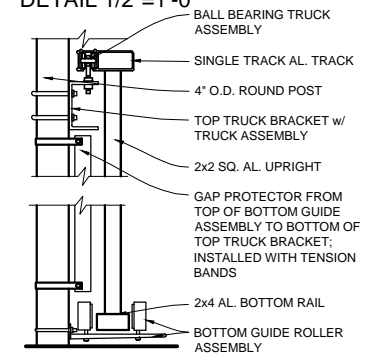

BOTTOM GUIDE ASSEMBLY
DETAIL 1/2"=1'-0"

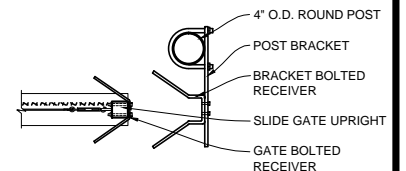

LATCH ASSEMBLY
PLAN DETAIL 1/2"=1'-0"

OPENING	OVERALL LENGTH	COUNTERBALANCE
INSIDE FACE OF POST TO INSIDE FACE OF POST	OUTSIDE OF FRAME TO OUTSIDE OF FRAME	OUTSIDE FACE OF POST TO OUTSIDE FACE OF POST
10'-0"	16'-10"	6'-6"
11'-0"	18'-10"	7'-6"
12'-0"	19'-10"	7'-6"
13'-0"	20'-10"	7'-6"
14'-0"	21'-10"	7'-6"
15'-0"	25'-4"	10'-0"
16'-0"	26'-4"	10'-0"
17'-0"	27'-4"	10'-0"
18'-0"	28'-4"	10'-0"
19'-0"	29'-4"	10'-0"
20'-0"	30'-4"	10'-0"
21'-0"	31'-4"	10'-0"
22'-0"	32'-4"	10'-0"
23'-0"	35'-4"	12'-0"
24'-0"	36'-4"	12'-0"
25'-0"	37'-4"	12'-0"
26'-0"	38'-4"	12'-0"
27'-0"	39'-4"	12'-0"
28'-0"	40'-4"	12'-0"
29'-0"	41'-4"	12'-0"
30'-0"	42'-4"	12'-0"

NOTES:

- SPECIFICATIONS SHOWN CAN BE CHANGED BY THE MANUFACTURER ONLY.
- ALL COMPONENTS OF THE PANEL TO BE MILL FINISH (UNCOATED)
- OUTSIDE LOOKING IN, GATE LATCHES ON RIGHT
- GATE WILL BE HUNG ON THE INSIDE OF THE FENCE LINE
- HEIGHT IS FROM GRADE TO TOP OF GATE. ACTUAL HEIGHT IS 3" LESS.
- BARB WIRE ARMS ARE 1'-0" HIGHER THAN THE GATE HEIGHT
- FOR GATES 8' OR HIGHER, THE BARB WIRE ARMS WILL BE BOLTED TO THE GATE. ALL HARDWARE WILL BE SUPPLIED.
- FOOTING & POSTS AS REQUIRED BY SITE CONDITIONS & CODES



COPYRIGHT © MERCHANTS METALS
 ALL RIGHTS RESERVED

Merchants Metals
the first name in fence solutions

SECURE TRAC CANTILEVER SLIDE GATE
 CHAINLINK w/ BARB WIRE

STANDARD GATE DESIGN FOR 10'- 30' OPENINGS

BY: DDD

DATE: 5.14.14

REV:

DWG. NO.

STCL10-30wBW

SCALE:

AS NOTED