

F-F: TYPICAL SPACING 48 1/2" POST FACE TO POST FACE .  
 SPACING CAN VARY DEPENDING ON GATE HARDWARE USED.  
 CONSULT GATE HARDWARE INSTRUCTIONS.

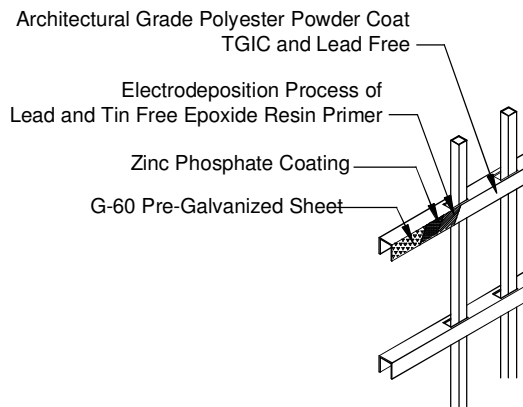

### Applicable Hardware:

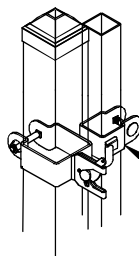

Gravity Latch

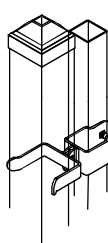

Fork Latch

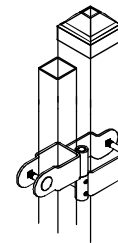

Gate Hinge

The product design contained on this drawing is proprietary to Fortress Iron, LP, Richardson, Texas, USA, and is not to be copied electronically or manually, or reproduced in any manner, or divulged to other sources, without the expressed written permission of an authorized representative of Fortress Iron L.P.



**Fortress Fence**  
 PO Box# 831268  
 Richardson, TX 75081

Style: <b>VERSAI EXT</b>	Description: <b>EXT-VERSAI-H" RES-04-AGP</b>	
Height: <b>46", 58", 70"</b>	Rev #: <b>0</b>	Rev Date: <b>8/5/14</b>
Gate Width: <b>46.5"</b>	Scale: <b>Do Not Scale</b>	
Class: <b>Residential</b>	Drawn By: <b>B B</b>	Date: <b>7/5/12</b>