

**Applicable Hardware:**

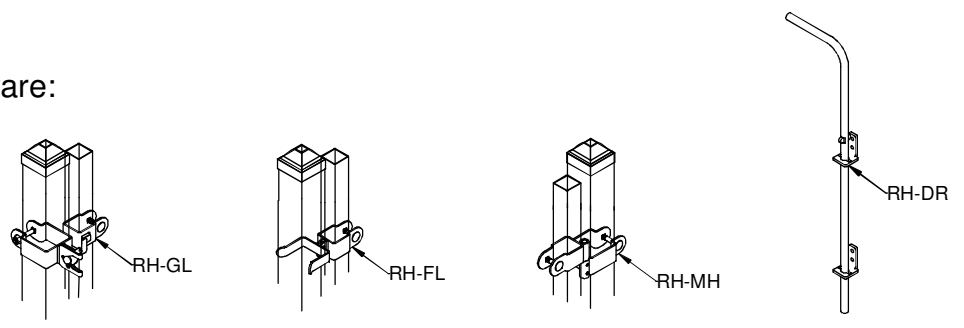

The product design contained on this drawing is proprietary to Fortress Iron, LP, Richardson, Texas, USA, and is not to be copied electronically or manually, or reproduced in any manner, or divulged to other sources, without the expressed written permission of an authorized representative of Fortress Iron L.P.

<p><b>Fortress Fence</b> PO Box# 831268 Richardson, TX 75081</p> <p>FENCE PRODUCTS A division of THE FORTRESS COMPANY www.fortressfence.com</p>	<p>Style: <b>VERSAI EXT</b></p>	<p>Description: <b>EXT-VERSAI-H" RES-08-DDGP</b></p>	
	<p>Height: <b>46", 58", 70"</b></p>	<p>Rev #: <b>0</b></p>	<p>Rev Date: <b>8/6/14</b></p>
	<p>Gate Width: <b>96"</b></p>	<p>Scale: <b>Do Not Scale</b></p>	
	<p>Class: <b>Residential</b></p>	<p>Drawn By: <b>BB</b></p>	<p>Date: <b>7/19/12</b></p>